

X-SPLASH



Mod.
X-10

1000 liters'
capacity



100% water
recycling



water saving

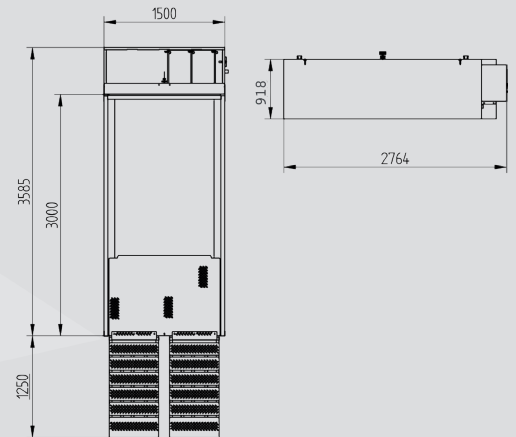

WASH BAY

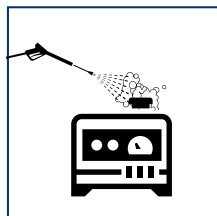
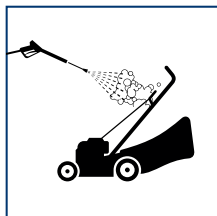

X-1

The **X-1** is the smallest version of the X-Splash available, designed for small plant and equipment.

X-1

How it works:

The wash bay is made with a diamond tread ramp and a 2200mm high wall. The wash bay floor pan directs the dirty water and sludge from the equipment being cleaned to a solids collection tank at the rear of the wash bay. Inside the rear tank, a float switch activates a diaphragm pump which delivers the dirty water into the filtration tanks to start the filtration process. After the water has been through this process, a booster pump delivers the water again to your pressure washer. Through the filtrating system, you can use the same water repeatedly. The filters inside the separator tank can be easily replaced, guaranteeing an adequate filtering barrier.

Advantages

- The system allows you to recycle water and therefore the contaminated water does not get into the drainage system;
- Less water used means more money is saved, and more savings made with handling and washing time;
- Easily transportable, easy to assemble and disassemble;
- Innovative design and the modular construction system make our wash bays suitable for several indoor and outdoor uses;
- Environmentally friendly.



SUITABLE FOR THESE SECTORS



**rental
companies**



**mechanical
workshops**



contractors



**industrial
applications**



Technical Specifications - X-Splash - X-1

Useful dimension mm.	1500x3000
Total dimension mm.	1500 x 4850
Filtration tank dimension mm.	(X-10) 2810 x 740 x 990h
Maximum load capacity kg	5.000
Walls standard height mm.	2200
Total dry weight of the bay kg	860
Diaphragm pump	0,054 kW - 17lt/min
Booster pump	0,37 kW - 5 to 40 lt/min.
Filtering system	X-10
Option filtering system	X-15, X-30, X-60
Option maximum load capacity kg	10.000/ 20.000



TRIME[®]
Water Treatments

Sales Dept. +39 0382 406 252
www.trime.it - info@trime.it